

# Operation Manual

Original Operation Manual

Article no.: 99988031E

Rev. 02 / 10.2019



## Double diaphragm pump

PTI-MHD1050



CE  II 2 G Ex h IIB T6-T4 Gb X

II 2 D Ex h IIIC 85-150°C Db X

We reserve the right to make technical changes relative to the presentations and information in this manual, that are necessary for improvement of the product characteristics.

All copyrights and industrial property rights to this product and all associated technical documentation remain with Timmer GmbH.

This manual is intended for everyone who is assigned to perform tasks on and with the pump. It contains guidelines and drawings that must not, neither in whole nor in part, be duplicated, disseminated used for competitive purposes, or communicated to other persons without authorisation.

All rights reserved.

Copyright 2019 Timmer GmbH

---

**Contents**



<b>1</b>	<b>EU Declaration of Conformity</b> .....	<b>5</b>
<b>2</b>	<b>About this manual</b> .....	<b>6</b>
2.1	Use and safekeeping .....	6
2.2	Manufacturer information .....	7
2.3	Areas of applicability .....	7
2.4	Warranty.....	8
<b>3</b>	<b>Safety</b> .....	<b>9</b>
3.1	Basic information concerning safety .....	9
3.2	Compliance with the instructions in the operating manual.....	10
3.3	Operational prerequisites .....	11
3.4	Intended use .....	11
3.5	Non-intended use.....	12
3.6	Foreseeable misuse.....	13
3.7	Signage on the pump.....	14
3.7.1	Rating plate .....	14
3.8	Personnel qualifications .....	15
3.9	Personal protective equipment .....	15
3.10	Safety notices in the operating manual.....	16
3.11	Safety instructions.....	17
<b>4</b>	<b>Additional ATEX information</b> .....	<b>20</b>
4.1	ATEX marking in accordance with Directive 2014/34/EU and DIN EN ISO 80079-36 for the pump .....	20
<b>5</b>	<b>Transport</b> .....	<b>22</b>
5.1	Check scope of delivery .....	22
<b>6</b>	<b>Storage</b> .....	<b>22</b>
<b>7</b>	<b>Product description</b> .....	<b>23</b>
<b>8</b>	<b>Installation</b> .....	<b>23</b>
8.1	Safety instructions.....	23
8.2	Preparations.....	25
8.3	Connection .....	25
<b>9</b>	<b>Commissioning</b> .....	<b>27</b>

9.1	Safety instructions .....	27
<b>10</b>	<b>Operation.....</b>	<b>29</b>
10.1	Regulating the delivery rate .....	29
<b>11</b>	<b>Fault rectification .....</b>	<b>30</b>
<b>12</b>	<b>Cleaning.....</b>	<b>32</b>
12.1	Safety instructions .....	32
<b>13</b>	<b>Maintenance .....</b>	<b>34</b>
13.1	Safety instructions .....	34
13.2	Maintenance schedule .....	35
13.3	Timmer Service .....	35
<b>14</b>	<b>Decommissioning .....</b>	<b>36</b>
14.1	Safety instructions .....	36
<b>15</b>	<b>Replacing components .....</b>	<b>37</b>
15.1	Safety instructions .....	37
15.2	Exploded-view drawing .....	39
15.3	Replacing the diaphragm .....	40
15.4	Replacing the pneumatic valve .....	42
15.4.1	Dismantling the pneumatic valve .....	45
15.4.2	Installation of the pneumatic valve .....	46
15.5	Replacing the ball valves and suction pipes .....	48
<b>16</b>	<b>Disposal.....</b>	<b>50</b>
16.1	Return shipment .....	50
<b>17</b>	<b>Technical data.....</b>	<b>51</b>
<b>18</b>	<b>Spare parts for standard version .....</b>	<b>53</b>
18.1	PTI-MHD1050, diaphragm 53509069 .....	53
18.2	PTI-MHD1050, diaphragm 53509070 .....	54

## 1 EU Declaration of Conformity

DESIGN: DOUBLE DIAPHRAGM PUMP

Type: PTI-MHD1050

ATEX marking:   II2G Ex h IIB T6-T4 Gb X  
II2D Ex h IIIC 85-150 °C Db X

The double diaphragm pump has been designed and manufactured in accordance with EU/EC directives:

Directive 2006/42/EC OJEU L157/24 of 17 May 2006

Directive 2014/34/EU, OJEU L 96/309 of 26 February 2014

under the sole responsibility of (manufacturer):

**Timmer GmbH**

**Dieselstrasse 37**

**D-48485 Neuenkirchen, Germany**

**www.timmer.de**

The following harmonised standards have been applied:

EN ISO 12100:2010 Safety of machinery –

General principles of design – Risk assessment and risk reduction

EN 809:1998+A1:2009 Pumps and pump units for liquids – Common safety requirements

EN ISO 4414:2010 Pneumatic fluid power - General rules and safety requirements for systems and their components

DIN EN ISO80079-36:2016: Explosive atmospheres - Part 36: Non-electrical equipment for explosive atmospheres– Basic method and requirements (ISO 80079-36:2016)

DIN EN ISO80079-37:2016: Explosive atmospheres - Part 37: Non-electrical equipment for explosive atmospheres - Non-electrical type of protection constructional safety "c", control of ignition sources "b", liquid immersion "k" (ISO 80079-37:2016)

Person responsible for compiling the documentation: Timmer GmbH

Address: See manufacturer

Neuenkirchen, 10.2019

City, date

  
\_\_\_\_\_  
Managing Director(Klaus Gehrman)

## **2 About this manual**

### **2.1 Use and safekeeping**

Please note the following points:

- The pump can only be appropriately and safely placed in service, operated and maintained with the aid of this operating manual.
- This operating manual refers only to the product that is specified on the cover sheet.
- This operating manual is a component of the scope of delivery.
- Consequently, always keep this operating manual in legible condition, on hand for the operator in the vicinity of the pump. Leave this document with the pump if the pump is resold or loaned out.
- This operating manual is intended only for instructed and authorised specialists.
- The section on safety provides an overview of all important safety aspects for optimal protection of personnel, and for safe and trouble-free operation of the pump.
- The manufacturer is not liable for damage resulting from failure to comply with the instructions in this operating manual.
- Reprints, translations and duplications in any form, including excerpts, requires the written consent of the publisher.
- The copyright remains with the manufacturer.

## **2.2 Manufacturer information**

### **Timmer GmbH**

Dieselstrasse 37

D-48485 Neuenkirchen, Germany

Tel.: +49 5973 9493-0

Fax: +49 5973 9493-90

info@timmer.de

**[www.timmer.de](http://www.timmer.de)**

## **2.3 Areas of applicability**

This product complies with the directives of the European Union.

In this regard, please note:

- This EU Declaration of Conformity
- The intended use
- The improper use

## **2.4 Warranty**

For all Timmer pumps, we grant the initial purchaser a one year warranty on workmanship and material starting from the date of purchase; provided that the pump is used as intended. Normal wear is excluded from the warranty. The warranty is invalidated automatically if the parts that are not original Timmer spare parts are installed in the Timmer pump.

In compliance with applicable law, Timmer GmbH excludes all liability for consequential damage. In all cases the liability of Timmer GmbH shall be restricted to and in no case shall exceed the equivalent value of the purchase price. Prior to purchasing and shipment of the Timmer pump, the customer should review the national and local laws and regulations to ensure that the product, the installation and the application are in compliance with the applicable regulations.

- Notify the manufacturer immediately of warranty claims after defects or faults are detected.
- In all cases the warranty shall be invalidated where liability claims cannot be legally asserted.
- Claims for modification of systems and components that have already been delivered cannot be asserted from the information, illustrations and descriptions in this operating manual.
- No liability is accepted for damage or malfunctions that occur as described below:
  - Disregard of the operating manual
  - Unauthorised modifications of the system
  - Operator error
  - Failure to perform maintenance tasks



## **3 Safety**

### **3.1 Basic information concerning safety**

The Safety chapter provides an overview of all important safety aspects for optimal protection of personnel, as well as for safe and trouble-free use of the pump, from transport to operation and extending to disposal.

Failure to comply with the instructions and safety notices cited in this operating manual can result in considerable hazards for personnel and material damage of pump.

The pump is operationally safe.

Nevertheless under the following circumstances residual risks can arise from the pump, if

- The pump is not used as intended.
- The pump is used improperly operated by untrained or uninstructed personnel.
- The pump is not properly maintained or serviced.
- The safety instructions, notices and warnings specified in this operating manual are not complied with.
- The pump is improperly modified or converted.
- The prescribed maintenance is not performed in a timely manner.

### **3.2 Compliance with the instructions in the operating manual**

Every person who is assigned to perform tasks on and with the pump must have read and under this operating manual, particularly the "Safety" chapter.

Knowledge of and compliance with the content of this manual is the prerequisite for protecting personnel from danger and avoiding error.

Consequently, all safety instructions must always be complied with, compliance is in the interest of your safety.

The operating manual is a component of the pump and must always be available in the vicinity of the product. The instructions in the operating manual must be complied with. If content of this operating manual is not clear or not understandable, contact the manufacturer without delay, see the paragraph "Manufacturer information".

In addition to the safety instructions in this operating manual the following guidelines and regulations must also be complied with:

- The intended use
- The applicable accident prevention regulations (UVV)
- Occupational medical health guidelines
- Generally accepted rules for safety
- Country-specific regulations
- The manufacturer information (safety data sheets) for operating materials and auxiliary materials, chemical substances

Moreover, these directives and regulations can be supplemented with work instructions that take into account plant-internal regulations or operational particularities.

In supplementation to this operating manual, company-internal instruction of the appropriate persons must be provided with due consideration of the technical qualifications.

### **3.3 Operational prerequisites**

Dependence on other systems and equipment must be tested by the owner separately.

Moreover, since they are not in our area of responsibility, the following prerequisites must be in place for regular operation of the pump:

- Properly concluded installation.
- Successful trial run with all required adjustment tasks.
- Instruction of operating personnel concerning operation of the pump and the applicable safety regulations.
- If hot or cold machine parts result in additional danger, then the customer must safeguard these parts from being touched.
- The possibility of hazards due to electrical energy must be excluded (for details in this regard see VDE guidelines or guidelines issued by the electrical utility, for example).
- The pump must be easily accessible.
- Designation of a person who is mainly responsible for proper operation.

### **3.4 Intended use**

- The pump and the operating manual are designed exclusively for commercial use.
- The pump may only be used for pumping liquid media (see chapter "Technical data").
- The pump must only be operated within the limits specified for intended use (see the chapter, "Technical data").
- The pumped medium must be compatible with the materials of the pump (see the chapter "Technical data").
- The owner of the pump is responsible for selection of the medium to be pumped.
- The pump must only be operated in environments that do not adversely affect the properties of the materials used.  
It is the responsibility of the owner to verify the suitability of the material.

### 3.5 Non-intended use

A use other than the use described in the section, "Intended use" and in this operating manual, and any use that extends beyond the specified intended use, is considered non-intended use. The manufacturer shall not be liable for damage resulting from non-intended use. This risk is borne solely by the user / owner.

- Pumping of media that does not meet the product specification
- Do not modify the pump in any manner whatsoever.
- Use of the pump for purposes other than those cited in section **Fehler! Verweisquelle konnte nicht gefunden werden.**
- Operating a damaged pump
- Operation, maintenance and repair of the system by unauthorised and/or untrained personnel
- Pump operation without earthing
- Pump operation outside of the specified parameters and/or operating data
- Operating the pump at a location where there are ignition hazards due to sources of ignition in the vicinity of the pump
- Use or commissioning of the pump by private users
- Modifying or converting the pump
- Set up on unsuitable substrates
- Attaching transport aids on the housing
- Failure to comply with the specified maintenance intervals
- Operating the pump in Zone 0 explosive gas/dust atmospheres
- Immersing the pump in the pumped medium
- Operation in explosive atmospheres without prior implementation of the requirements stipulated in Directive 1999/92/EC and national regulations for explosion protection, on the part of the owner
- Initial commissioning without prior inspection of the area and the pump by a person qualified to perform the inspection
- Pumping of media that is chemically incompatible with the materials used to construct the pump – The owner of the pump must check the chemical compatibility of the pumped media
- Pumping of media with parameters (e.g. ignition temperatures) that are not compatible with the information specified on the pump
- Operating the pump with bypassed safety devices is prohibited

### **3.6 Foreseeable misuse**

The following points describe foreseeable misuse of the pump:

- Installation on unsuitable grounds or flooring
- Attachment of transport aids on the housing
- Failure to comply with the operating data
- Failure to comply with the maintenance intervals
- Operation with unsuitable media
- Operation in the wrong Ex zone

### 3.7 Signage on the pump

The data on the rating plate affixed on the pump must always be complied with. The rating plate must not be removed, and it must be kept in completely legible condition.

#### 3.7.1 Rating plate

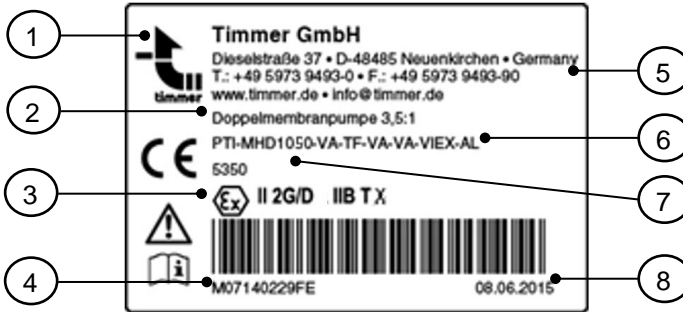

Fig. 1: Rating plate

- |   |  |   |                      |
|---|--|---|----------------------|
| 1 | Logo   | 5 | Manufacturer address |
| 2 | Product designation                                  | 6 | Type key             |
| 3 | ATEX marking according to RL2014/34/EU to be adapted | 7 | Article number       |
| 4 | Serial number  | 8 | Date                 |

### 3.8 Personnel qualifications

Tasks on the pump must only be performed in accordance with existing rules and statutory regulations, by personnel who have been instructed and are qualified in this regard, in compliance with due diligence obligations.

The following requirements must be fulfilled:

- Personnel must have special skills and experience in the respective technical area. This particularly applies for maintenance and repair tasks on mechanical and pneumatic fixtures of the pump.
- Personnel must have knowledge of applicable standards, directives, accident prevention regulations and operating conditions.
- Personnel must have been authorised by the person responsible for safety to perform the respectively required tasks.
- Personnel must be capable of recognising and avoiding possible dangers.

The required personnel qualifications are subject to different statutory regulations depending on the implementation site. The owner must ensure compliance with the applicable laws.

### 3.9 Personal protective equipment

Failure to wear the personal protective equipment can result in severe injury or death.

- Wear the plant prescribed protective equipment, e.g. hearing protection, eye protection, safety footwear, hard hat, protective clothing, and protective gloves for all tasks on the pump.



- Long hair must be tied back and covered; do not wear loose clothing or jewellery. Danger of injury through entrapment, being pulled in or entanglement due to moving parts.
- Ensure that there are no unauthorised persons in the danger zone.

**3.10 Safety notices in the operating manual** **WARNING**

The signal word **WARNING** indicates a possible danger.  
Failure to comply with the instruction can result in severe or fatal injury.

---

 **CAUTION**

The signal word **CAUTION** indicates a possible danger.  
Failure to comply with the instruction can result in minor to moderate injury.

---

**! Attention**

The signal word **Attention** indicates possible material damage.  
Failure to comply with the instruction can result in machine damage.

---

 **Environmental protection notice**

The signal word **Environmental protection notice** indicates information on environmental protection.

---

 **Note**

The signal word **Note** indicates additional information for the machine its use.



### 3.11 Safety instructions

#### **CAUTION**

##### **Danger to persons by a defective pump!**

- Check the pump regularly for damage and leaks.
- Switch off a damaged or leaking pump immediately.

#### **CAUTION**

##### **Health impairment due to contact with harmful media!**

- Only perform cleaning, repairs, troubleshooting and fault rectification in which the possibility of contact with the medium cannot be excluded, if beforehand you have put on the appropriate personal protective equipment PPE (at least protective clothing, protective gloves, protective goggles).
- Comply with the safety data sheets of the manufacturers and the national laws and directives.
- Depending on the operating conditions and the mode of operation of the pump, medium can escape at the silencer in the event of a diaphragm rupture. The released medium can accumulate inside the pump and be released into the environment during longer faulty operation. Therefore, necessary safety measures are to be taken during operation, maintenance and repair depending on the medium.

#### **Attention**

##### **Damage to the pump due to the operating conditions and properties of the pumped media!**

- The characteristics of the pump media (such as abrasiveness, viscosity, etc.) and the operating conditions can negatively influence the service life and the operation of the pump.
- Solids in the media can damage the pump, especially the diaphragm, and cause an immediate breakdown.

## Attention

### **Pump damage due to chemical incompatible media!**

- The owner of the pump must check the chemical compatibility of the pumped media with the materials used to construct the pump.  
A list of the materials used in the pump is provided in the chapter “Technical data”.

## Attention

### **Damage to the pump due to high mechanical forces!**

- Do not subject the pump to major mechanical forces.

## Attention

### **Destruction of the pump due to excessive air pressure!**

#### **Excessive air pressure can destroy the diaphragm and cause the pump to burst.**

- Operate the pump with compressed air pressure of maximum 6 bar.
- Ensure that the exit point of the pumped medium is not clogged or sealed.

## **WARNING**

### **Danger of explosion due to improper installation tasks!**

- During installation and dismantling, maintenance, transport to/from the place of use, and maintenance there is danger of generating sparks through friction, impact and rubbing processes or through electrostatic charging. Consequently, ensure that these hazards are safely eliminated or that an explosive atmosphere is not present during these work stages.

 **WARNING****When handling dangerous substances:**

The following instructions must be complied with if the hazard analysis conducted by the owner reveals that a possible leak of the medium poses an increased risk:

- The installation of media shut-off valves at the medium inlets and outlets to shut off the medium flow in case of a leakage on the pump.
- The installation of the pump with shut-off valve, 3-way valve and check valve in the compressed air supply line. These 3 components prevent the pumped medium from entering the compressed air system if a diaphragm tears.
- If diaphragms are completely defective, the fluid can enter the compressed air circuit, damage the compressed air circuit and exit via the silencer. Depending on the pumped medium, the silencer must be replaced by a suitable pipe or hose connection to avoid danger. The discharge must be taken to safe place.
- If diaphragms are completely defective, the medium to be pumped can react with materials in the compressed air circuit. Prior to commissioning the owner must assess the risk and take suitable measures.

**Environmental protection notice****Environmental pollution due to pumped media and cleaning agents.**

- Regularly check all lines, hoses and connections for leaks and apparent damage. Immediately repair any damage!
- Take up or wipe up leaked and spilled media and cleaning agents and dispose of them in an eco-friendly manner.
- Prevent escaped or spilled media and cleaning agents from getting into the groundwater.
- For safe and eco-friendly disposal of media, cleaning agents and replacement parts.
- Comply with the safety regulations applicable to the media and cleaning agents.

## 4 Additional ATEX information

### 4.1 ATEX marking in accordance with Directive 2014/34/EU and DIN EN ISO 80079-36 for the pump

**CE**  **2G Ex h IIB T6-T4 Gb X / 2D Ex h IIIC 180 °C Db X**

Symbol	Meaning
<b>CE</b>	CE mark.
	Marking relevant for explosion prevention in accordance with ATEX.
II	Atex device of Equipment Category II intended for use in explosive atmospheres, except for mines.
h	Non-electrical device for the explosive area.
2 G/D	ATEX device of Equipment Category 2 (avoidance of effective ignition sources). The device can be used as intended in areas where Zone 1 and Zone 2 explosive gas or dust atmospheres can occur. Use of the device is prohibited in Zone 0.
IIB	The intended use is permitted in gas explosive areas with gases and vapours of explosion groups IIA and IIB. The intended use is not permitted in gas explosive areas with gases and vapours of explosion group IIC.
IIIC	Use as intended in potentially explosive dust atmospheres with dusts of dust groups IIIA, IIIB and IIIC
T6-T4	Temperature class for the gas explosion hazardous area. The actual maximum surface temperature does not depend on the device; but rather it depends on the operating conditions (medium temperature and compressed air temperature).
T85°C- T150 °C	Surface temperature for the area with a dust explosion hazardous area. The actual maximum surface temperature does not depend on the device; but rather it depends on the operating conditions (medium temperature and compressed air temperature).
Gb/Db	Device protection class for gas or dust. In normal operation and for the faults that can usually be expected (defects on the device), the device ensures the required degree of safety and avoidance of ignition sources.
X	The following special conditions must be met to ensure safe operation of the pump in explosive atmospheres. Pay attention to the limited ambient temperature. Mechanisms/processes that generate stronger charges than are generated through manual rubbing, must be prevented on the labels, the silencer and possibly the diaphragm.

 **WARNING**

Danger due to highly effective charge-generating processes!

- Highly efficient charge-generating processes can cause electrostatically dangerous charging of diaphragms that have a non-dissipative layer (e.g. PTFE) on the media side. Highly-effective processes that generate static charges, include flaring of multiphase fluids and liquids with low conductivity ( $< 100 \text{ pS/m}$ ) and the purging of the pump with compressed air.  
The owner must take additional protective measures to safely prevent these processes. Possible measures include:
    - Filling the pipes and pump chambers with inert gas during dry-run
    - Slow filling and emptying of the pump
    - Reliable avoidance of dry-run (slurp operation)
  - Highly-effective charge-generating processes can cause electrostatic charging of labels/stickers, silencers and ball valve handles. Highly efficient processes that generate charges include cleaning the pump with a high-pressure cleaner.  
The owner must take additional protective measures to safely prevent these processes. Possible measures include:
    - Large-area, permanent covering of the labels/stickers with transparent conductive foil, or the removal of such labels/stickers (rating plates must not be removed).
    - Replacement of the silencer with a conductive/dissipative silencer.
- 
- 

 **WARNING**

Danger of explosion due to hot surfaces!

The maximum surface temperature is equal to the max. temperature of the pumped medium and/or the compressed air temperature.

- In accordance with national regulations, the medium temperature/compressed air temperature must with certainty and with a sufficient differential, be below the ignition temperature of the explosive atmosphere.

### 5 Transport

Transport the pump only in its original packaging as far as possible to prevent transport damage.

#### 5.1 Check scope of delivery

1. Remove the transport packaging of the pump.
2. Dispose of the packaging material correctly.
2. Examine the pump for transport damage.
  - Immediately notify the transport company and the manufacturer of transport damage in writing.
  - Protect the pump from further damage.
3. Use the packing slip to verify the completeness of the delivery.

### 6 Storage

- The storage conditions influence the service life of the diaphragm.
- The pump must only be stored for safekeeping if it has been thoroughly cleaned beforehand.
- Extreme storage conditions accelerate the ageing process.
- We recommend a storage temperature between +10°C and +25°C.
- The high-pressure diaphragms must not be exposed to heat sources or direct sunlight.
- Exclude the possibility of influence of ozone or ionising radiation.
- Store the diaphragm in unstressed condition.
- We recommend to replace the diaphragm at the latest after one year storage under the above-mentioned storage conditions.

## 7 Product description

The double diaphragm pump is a self-priming, pneumatically-powered fluid pump. The liquid is pumped through the opposite movement of two diaphragms. A reversing valve ensures that the two diaphragms are alternately charged with compressed air. Each diaphragm comprises a liquid inlet valve and liquid outlet valve.

When the diaphragm is enlarged due to the movement of the pump chamber, the outlet valve closes and the inlet valve opens so that the liquid is sucked into the pump chamber. When the diaphragm is moving in another direction, the pump chamber becomes smaller, the inlet valve closes, the outlet valve opens and the liquid is sucked out.

When one of the diaphragms reaches its end position during the suction process, the end switch operates the reversing valve so that the other diaphragm is charged with air.

The reversing valve is designed in such a way that it cannot stay in the central position.

## 8 Installation

### 8.1 Safety instructions

#### **WARNING**

##### **Personnel are in danger due to improper installation!**

- Connections must be used that are made of material that is compatible with the pumped medium and with the material of the pump.
- The pump does not have its own pneumatic shut-off valve. If the pump cannot be switched off by simply, safely disconnecting or switching off the compressed air supply, an additional, easily accessible shut-off valve must be installed upstream of the compressed air connection.
- The pump must be integrated in the compressed air system in such a manner that it can be taken out of service by switching off the compressed air.
- Select the installation location for the pump in such a manner that the possibility of impacts that can cause ignition is excluded.
- The compressed air supply (hoses, etc.) must be installed in such a manner that they do not pose any hazard.
- Use a pressure relief valve in the compressed air supply if there is a risk of exceeding the operating parameters.

### **WARNING**

#### **Danger of explosion due to electrostatic charge!**

- Connect the pump before the start-up to the protective earth system (potential equalisation).

### **WARNING**

#### **Personnel are in danger due to improper installation!**

- Installation tasks must only be executed by trained personnel.
- Wear personal protective equipment (PPE).

### **CAUTION**

#### **Personnel are in danger due to inadequate lighting!**

- Only perform installation tasks on the pump in an adequately illuminated and air-conditioned environment.

### **! Attention**

#### **Multifunction or damage due to residual substances in the pump**

- Prior to commissioning purge the pump with suitable media to remove from the pump interior any substances introduced during the customer process (goods receipt, handling, storage, installation, etc.) that may impair paint wetting, substances that are incompatible with the pumped medium.
- For this, section 12 Cleaning must be complied with



## 8.2 Preparations

- Do not use the pump as support for the pipeline system.
- Ensure that the system components are properly supported to prevent stress on the pump parts.
- Make sure that the provisions regarding the protective earth system (potential equalisation) are met.

### ► Note

- An electrical connection is not required.
- The pump is self-priming.

## 8.3 Connection

1. Install the pump on a horizontal, level surface with the pump base down. The pump operates only in this position.
2. Make sure the pump is in a stable position by fixing using suitable fixing screws.  
Do not immerse the pump into the pumped medium.
3. Install a compressed air hose from the compressed air source to the pump.  
There is a G ½" (1) connection thread on the pump.

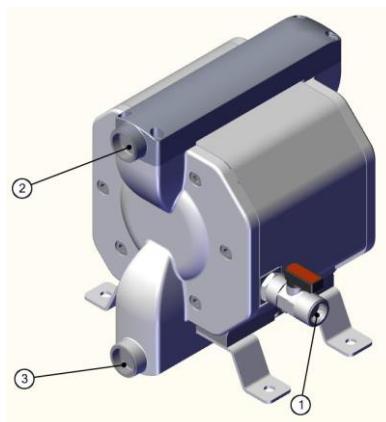

Fig. 2: Pump connections

## Installation

---

4. Use flexible connections (for example hose connections) for intake and delivery.  
Flexible connections prevent the transmission of vibrations to the pipeline system.
5. Ensure that the connectors are compatible with the medium to be conveyed and are able to withstand high pressures.
6. Dimension the piping cross-sections sufficiently large.  
The sizes depend on the medium viscosity and the situation of the equipment.
7. Use suitable hose clamps to connect the intake and delivery hose.
8. Connect the intake hose with the entry point (3).
9. Connect the delivery hose with the exit point (2).
10. Connect to the pump with the protective earth system.  
The connection for the potential equalisation is correspondingly marked at the pump base (4).

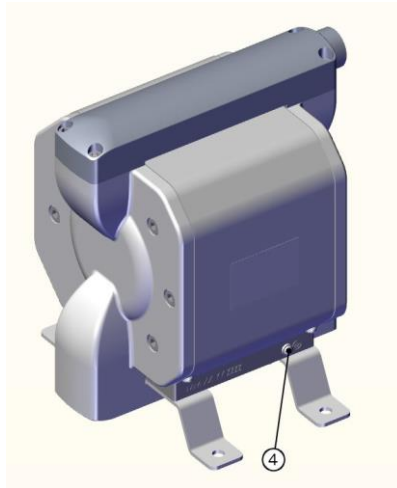

Fig. 3: Connection for the potential equalisation

11. Check all connections for tightness and proper seating.
12. Connect the compressed air hose to the compressed air connection of the pump.

## 9 Commissioning

### 9.1 Safety instructions

#### **WARNING**

##### **Danger of explosion due to dust on the pump housing!**

- Regularly clean the surface of the pump housing and remove the dust layers.

#### **WARNING**

##### **Life-threatening danger due to pumping explosive media in hazardous areas!**

**The medium to be pumped can corrode or otherwise damage components of the pump and escape. This can result in an explosive mixture.**

- Pumping of explosive media or gases is prohibited
- The intended use in the Ex environment is only possible in due compliance with Directive 2014/34/EU, in accordance with the marking on the rating plate of the pump:

CE  II 2 G Ex h IIB T6-T4 Gb X

II 2 D Ex h IIIC 85-150 °C Db X

 **WARNING****Life-threatening danger when operating the pump in hazardous areas!**

- The pump may be used in explosive areas (for example paint shops), only if this is appropriately indicated on the pump rating plate.
- Moreover the owner of the pump is obligated to comply with the requirements stipulated in Directive 1999/92/EC.
- The pump may only be used in explosive atmospheres (e.g. paint shops) if the ATEX markings on the rating plate of the pump and its sub-devices meet the requirements of the zone classification.
- During operation, ensure that the pump is always completely filled with fluid. The continuous pumping of ignitable gas/fluid mixtures that cause a Zone 0 to occur inside the pump, is prohibited.
- The pumped medium can react exothermally with the material of the pump. Before pumping the medium, check the suitability of the pump materials for the medium to be pumped.
- Operation of the pump above the permissible flow rate and longer dry-run operation can cause overheating of the pump.
- When pumping media in ring systems, the delivery capacity of the pump is converted into heat. For short lines, this can cause dangerous heating of the medium.
- Operation of the pump can adiabatically compress explosive gas mixtures in the pump and/or the piping system. This can result in increases in temperature that pose an ignition hazard. The owner must take appropriate measures. The media outlet must not be closed during pump operation.
- The special operating conditions of the pump must be noted and complied with.

## Attention

### **Destruction of the pump due to excessive air pressure!**

**Excessive air pressure can destroy the diaphragm and cause the pump to burst.**

- Operate the pump with compressed air pressure of maximum 6 bar.
- Ensure that the exit point of the pumped medium is not clogged or sealed.

1. If the pump is not installed on a horizontal, level surface with the pump base mounted downwards, vent the pump chambers.
2. Set the compressed air to 1 ... 6 bar.  
The pump is ready for operation.
3. Open the ball valve for the compressed air supply.  
The pump starts pumping.
4. Operate the pump with compressed air pressure of maximum 6 bar.

## **10 Operation**

### **10.1 Regulating the delivery rate**

#### **► Note**

If the delivery rate of the pump must be regulated, the owner has to install a throttle valve into the compressed air supply or into the delivery line.

#### **Reducing the delivery rate**

- Reduce the compressed air supply or the medium outlet.

#### **Increasing the delivery rate**

- Increase the compressed air supply or the medium outlet.

**11 Fault rectification**

<b>Fault</b>	<b>Cause of the error</b>	<b>Error rectification</b>
Pump not running or is running too slow	Insufficient compressed air pressure	Set pressure at 4 to 6 bar
	Cross section of the hose is too small	Use a hose with a larger cross section
	Control valve leaking	Renew control valve and seals
	Blockage of the sound absorbers, pump running heavily, seal is welled or piston material damaged	Check material strength, avoid dry running
Pump is running but does not pump the medium or stops when the pressure side is shut off	Valves clogged	Clean the pump with detergent
	Delivery hose clogged	Clean delivery hose
	Suction and pressure valves clogged	Run the pump for 10 to 20 minutes at top speed
	Connections leaking, possibly intake of tramp air, vacuum collapses	Check connections for leak and re-seal
	Valves clogged	Clean or renew the valves
	No suction at suction and pressure ends	Put your hand over the openings to feel the suction effect and, if necessary, replace the seals
	Excessive medium viscosity	High-viscous media cannot be delivered (see chapter "Technical data" for the limit values)
	Delivery hose has cracks or has holes the size of pin holes	Replace conveyor hose

<b>Fault</b>	<b>Cause of the error</b>	<b>Error rectification</b>
	Counter pressure at the injection point is too high	Reduce the counter pressure at the injection point
	Threaded fittings, ball valve or non-return valve have no passage or reduced passage	Re-establish flow-through: clean or replace affected fittings
	Air in the pump chamber	Vent the pump
Fluid container runs empty autonomously	Exit point of the fluid is lower than the fluid level in the container	Place the fluid container lower or the exit point higher

**12 Cleaning****12.1 Safety instructions****Attention****Pump damage due to hardening, crystallising media!**

- When pumping fluids that contain solids that harden, crystallise, or that can corrode pump materials due to chemical or physical properties, the pump must be cleaned before longer standstill periods!
  - A longer standstill period is defined depending on the previously pumped medium and the change of its aggregate state from fluid to solid.
  - The definition is the responsibility of the owner and must be complied with in any case to avoid pump damage.
- 

1. Only clean the pump with a cleaning agent that is suitable for the pump material and the conveyed material.  
Water or solvents may be suitable.  
Liquid and solid detergents must not exceed a temperature of 65 °C.
2. Connect the suction pipe connection with the detergent.
3. Connect the media outlet to a suitable container.
4. Pump the cleaning agent until all residues are detached from the pump.
5. Completely empty the pump.
6. To do this, pull the suction hose out of the cleaning agent far enough that air is suctioned in.
7. One cleaning agent no longer comes out of the outlet, disconnect the media outlets of the pump completely.
8. Swivel the pump to empty completely 90° to the connection side so that the media connections point down.

**► Note**

In the case of shutdown and placing in storage a complete emptying of the pump is necessary because the cleaning liquid may accelerate the ageing of the pump diaphragm.

9. Operate the pump with compressed air pressure of approx. 1 bar.



- 
10. During that move the pump slightly back and forth until the remnant as all run out.
  11. Clean the outer parts of the pump.

**Cleaning before decommissioning**

1. Clean and empty the pump as described in the preceding paragraph.
2. Replace the pump the latest one year after storage at the latest because it is subject to normal ageing and to ensure a safe and reliable operation of the pump.  
Extreme storage conditions can accelerate the ageing process.

### 13 Maintenance

#### 13.1 Safety instructions

#### **WARNING**

**Personnel are in danger due enclosed compressed air and pressurised medium!**

- Do not service or clean the pump, hoses and the outlet valve for the compressed air while the system is pressurised.
  - Before performing tasks on the pump de-pressurise the pneumatic section and the fluid section.
  - Shut off the compressed air supply and wait until the residual pressure is dissipated via the outlet valve for the compressed air.
  - Empty the pump before replacing components.
- 

#### **WARNING**

**Hazard for personnel due to spraying fluids (media)!**

- Ensure that the material hoses and other components can withstand the fluid pressure generated by this pump.
  - Check the pump for damage or wear on a regular basis.
  - Ensure that the pneumatic valve, the outlet area for the compressed air and the suction side and pressure side are clean and functioning effectively for the medium.
  - Depressurise the pump before dismantling. Under some circumstances, a slight residual pressure may still be present in the pressure chamber causing the medium to eject.
  - For dismantling tasks on the pump comply with the information in the safety data sheets of the previously pumped medium.
  - Depending on the operating conditions and the mode of operation of the pump, medium can escape at the silencer in the event of a diaphragm rupture. The released medium can accumulate inside the pump and be released into the environment during longer faulty operation. Therefore, necessary safety measures are to be taken during operation, maintenance and repair depending on the medium.
-

 **WARNING****Personnel are in danger due to improper installation!**

- Installation tasks must only be executed by trained personnel.
- Wear personal protective equipment (PPE).

 **CAUTION****Personnel are in danger due to inadequate lighting!**

- Only perform installation tasks on the pump in an adequately illuminated and air-conditioned environment.

The double diaphragm pump is resistant to wear except for high-pressure diaphragm. The quality of the compressed air supply, the characteristics of the pumped media (such as abrasiveness, viscosity, etc.) and the operating conditions can negatively influence the service life of the pump.

Consequently we recommend regular inspection of the pump and the pump valve.

Nevertheless, should a fault occur, or if the delivery capacity decreases, you can perform the following tasks:

- Replace the high-pressure diaphragm
- Clean the liquid valves
- Replace the steels
- Clean and grease the pneumatic valve

### 13.2 Maintenance schedule

Prepare maintenance plan on the basis of the service life of the pump.

Such a maintenance plan with maintenance intervals is particularly important to reach a small operation of the pump.

### 13.3 Timmer Service

We recommend having Timmer Service perform all recurring maintenance tasks, particularly for the entire pneumatic unit.

Timmer offers a comprehensive service concept in this regard.

### 14 Decommissioning

#### 14.1 Safety instructions

#### **WARNING**

##### **Personnel are in danger due to improper installation!**

- Installation tasks must only be executed by trained personnel.
  - Wear personal protective equipment (PPE).
- 

#### **CAUTION**

##### **Health impairment due to contact with harmful media!**

- Only perform cleaning, repairs, troubleshooting and fault rectification in which the possibility of contact with the medium cannot be excluded, if beforehand you have put on the appropriate personal protective equipment PSA (at least protective clothing, protective gloves, protective goggles).
  - Comply with the safety data sheets of the manufacturers and the national laws and directives.
- 

Shut off the compressed air supply to the pump if the system will not be used for a longer period.

## 15 Replacing components

### 15.1 Safety instructions

#### **WARNING**

##### **Personnel are in danger due to improper installation!**

- Installation tasks must only be executed by trained personnel.
- Wear personal protective equipment (PPE).

#### **WARNING**

##### **Hazard for personnel due to spraying fluids (media)!**

- Ensure that the material hoses and other components can withstand the fluid pressure generated by this pump.
- Check the pump for damage or wear on a regular basis.
- Ensure that the pneumatic valve, the outlet area for the compressed air and the suction side and pressure side are clean and functioning effectively for the medium.
- Depressurise the pump before dismantling. Under some circumstances, a slight residual pressure may still be present in the pressure chamber causing the medium to eject.
- For dismantling tasks on the pump comply with the information in the safety data sheets of the previously pumped medium.
- Depending on the operating conditions and the mode of operation of the pump, medium can escape at the silencer in the event of a diaphragm rupture. The released medium can accumulate inside the pump and be released into the environment during longer faulty operation. Therefore, necessary safety measures are to be taken during operation, maintenance and repair depending on the medium.

### **WARNING**

#### **Personnel are in danger due enclosed compressed air and pressurised medium!**

- Do not service or clean the pump, hoses and the outlet valve for the compressed air while the system is pressurised.
- Before performing tasks on the pump de-pressurise the pneumatic section and the fluid section.
- Shut off the compressed air supply and wait until the residual pressure is dissipated via the outlet valve for the compressed air.
- Empty the pump before replacing components.

### **CAUTION**

#### **Personnel are in danger due to inadequate lighting!**

- Only perform installation tasks on the pump in an adequately illuminated and air-conditioned environment.

### **Attention**

#### **Pump damage due to incorrect tightening torque of the housing screws!**

- The prescribed tightening torque for the cylinder screws of the housing cover is 18 Nm.
- To prevent damage and leaks of the pump, the value must be complied with.
- Use a calibrated dynamometric key.

## 15.2 Exploded-view drawing

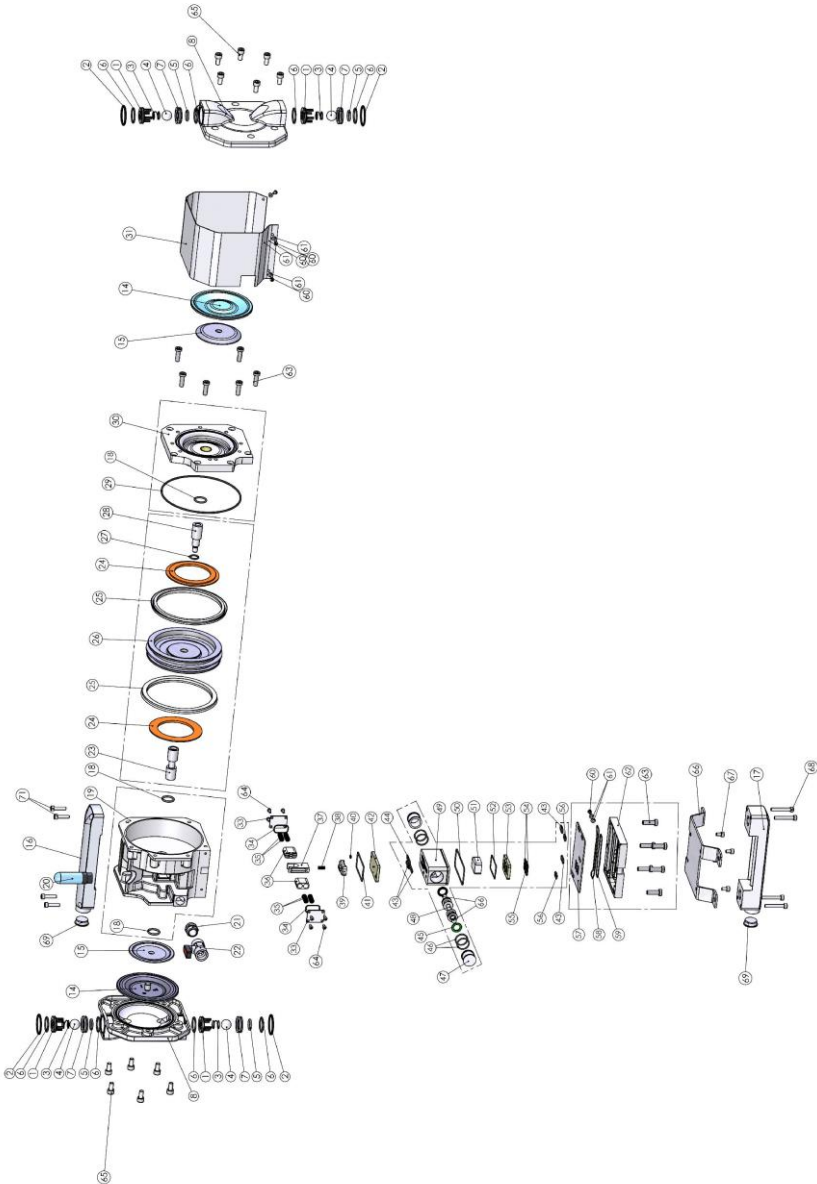

Fig. 4: Exploded-view drawing

### 15.3 Replacing the diaphragm

#### ► Note

- When changing the membrane, a change of support discs is imperative because due to the high load the support disc has only a limited lifetime.
- Timmer GmbH disclaims all warranties if the diaphragm is changed without changing the support disc.

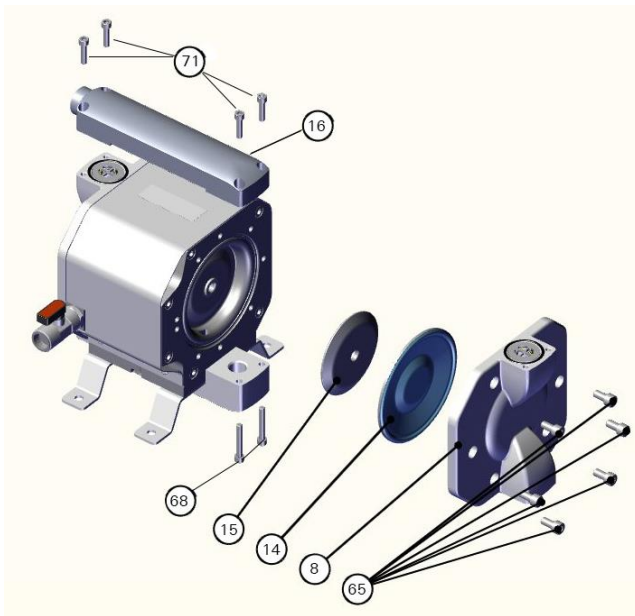

Fig. 5: Replacing the diaphragm

1. Loosen the fillister head screws (68, 71 and 65) at one of the housing covers (8) and remove the cover (8) at the pressure pipe (16).
2. Remove the diaphragm (14) and the support disc (15) from the piston rod by turning counterclockwise.
3. Place the new diaphragm (14) onto the new support disc (15) and screw both parts in a clockwise direction on the piston rod.



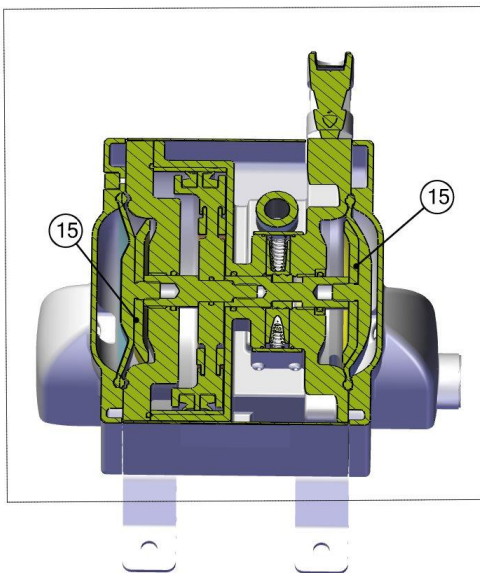

Fig. 6: Installation of the support disc

Observe the installation direction of the support disc (15 - see figure).

4. Assemble the housing cover (8) with fillister head screws (65).
5. Then tighten all screws with a torque of 18 Nm.

### 15.4 Replacing the pneumatic valve

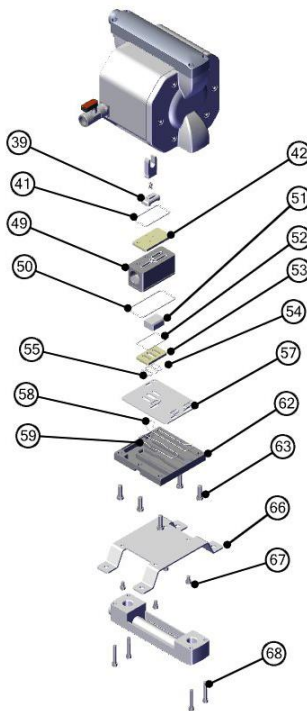

Fig. 7: Replacing the pneumatic valve

1. Loosen the fillister head screws (68) from the suction pipe and remove the suction pipe.
2. Loosen the fillister head screws (67) from the retaining plate and remove the retaining plate (66).
3. Loosen the fillister head screws (63) on the base plate (62) and remove the base plate.
4. Remove the O-rings (58) and (59), the intermediate plate (57), the O-rings (54), (55) and (52), the ceramic plate (53) and the O-ring (50).

5. Remove the assembled pneumatic valve (49) using the pulling hammer.



Fig. 8: Pulling hammer

6. Do this, position the hook of the pulling hammer in the main valve body in the middle under the main valve piston.

## Replacing components

7. Remove the pneumatic valve (49) by a rapid upward movement of the hammer piston out of its seat.

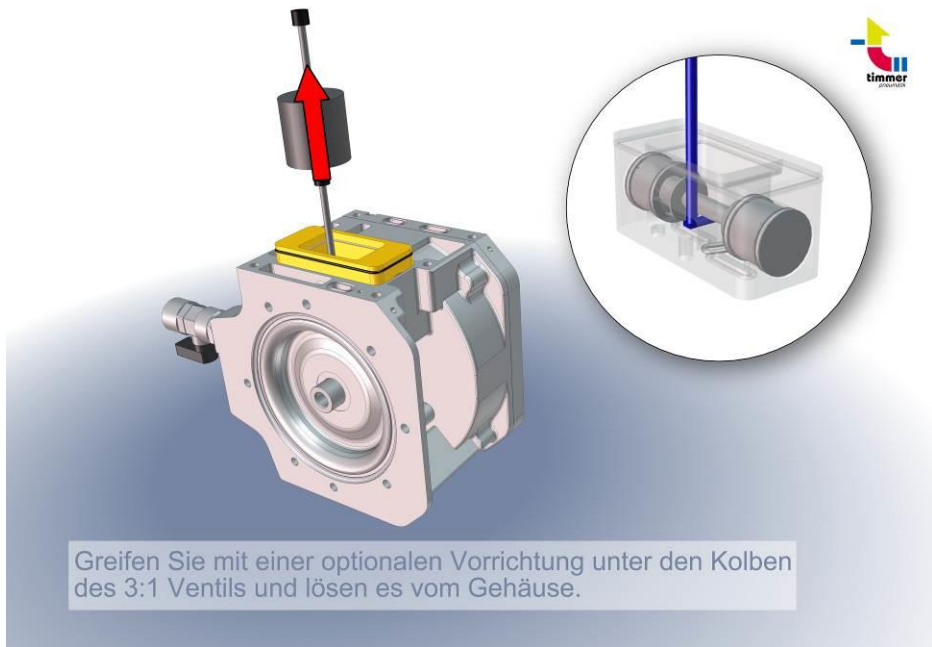

Fig. 9: Application of the pulling hammers

8. Remove the ceramic plate (42), the O-rings (21) and (20) and the control valve obturator (19).

### 15.4.1 Dismantling the pneumatic valve

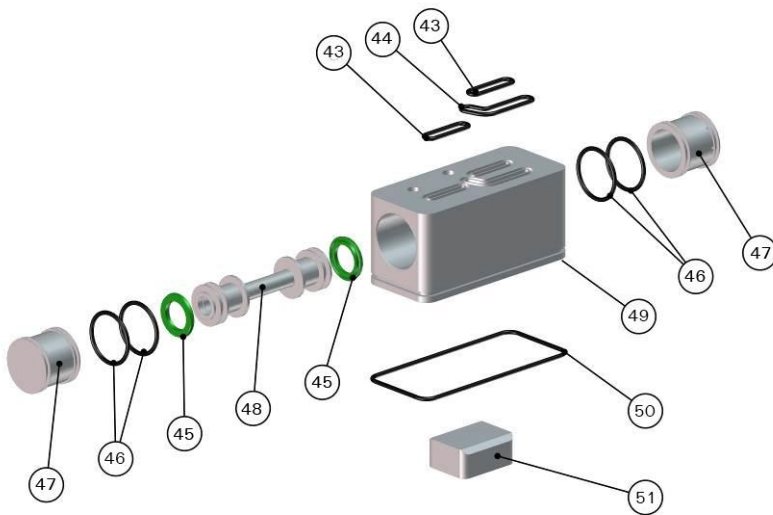

Fig. 10: Dismantling the pneumatic valve

1. Remove the O-rings (43) and (44) from the grooving of the pneumatic valve block (49).
2. Take the main valve obturator (51) out of the pneumatic valve block (49).
3. Remove the caps (47) with the O-rings (46).
4. Remove the pusher (48) with the piston seals (45) from the pneumatic valve block (49).
5. Remove the O-ring (50) from the outer groove of the pneumatic valve block (49).
6. Clean the parts with a suitable cleaning agent!  
Previously, check the media compatibility!
7. Check the parts, especially the O-rings and replace defective parts.

### 15.4.2 Installation of the pneumatic valve

1. Place the O-rings (40) and (41) into the grooves in the centre piece of the pump.  
The O-rings keep their position better if they are greased.
2. Place the control valve obturator (39) with the narrow side in front into the middle of the pump.

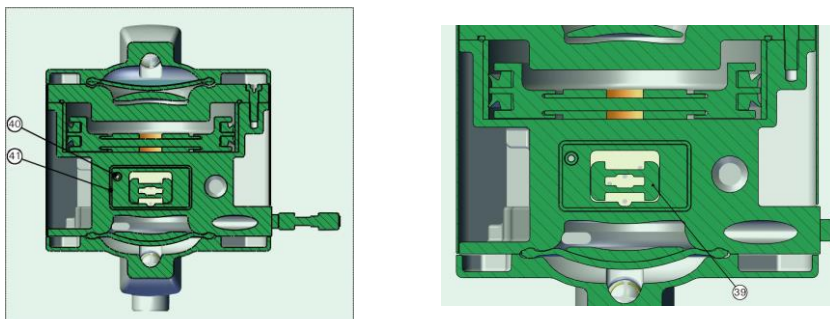

Fig. 11: Position of the ceramic plate and the pneumatic valve block

3. Insert the ceramic plate (42) into the middle section of the pump so that a hole aligns with the O-ring (40) (see Fig. 11, left).
4. Mount the pneumatic valve block (49) in reverse order.
5. Before mounting, lubricate the seals and O-rings (e.g. With Fuchs® Renolit Unitemp 2) and avoid any damage to the seals and O-rings when mounting.
6. Install the piston seals (45) onto the pusher (48) so that the sealing lips face each other.
7. Insert the pusher (48) into the pneumatic valve block (49).
8. Reinstall the O-rings (46) on the caps (47) and mount the caps (47) from the side into the pneumatic valve block (49).
9. Insert the O-ring (50) into the outer groove of the pneumatic valve block (49).
10. Place the O-rings (43) and (44) into the groove of the pneumatic valve block (49).  
During assembly, make sure that the O-rings do not get out of the grooves and get damaged.
11. Insert the mounted pneumatic valve block (49) into the middle section of the pump.

The mounting direction is shown by the opening on the pneumatic valve block (49) and the recess in the centre piece of the pump (see Fig. 11, right).

12. Insert the main valve obturator (51) with the close side in front into the pneumatic valve block (49). The main valve (51) must be inserted so that the valve (48) can move it.
13. Place the O-rings (52), (54) and (55) into the ceramic plate (53).
14. Insert the ceramic plate (53) into the pneumatic valve block (49).  
Make sure the installation is correct (side with the large O-ring (52) first).
15. Place the O-rings (43) and (56) into the central part of the pump provided for this purpose.  
Ensure that the O-rings are not damaged or get out.
16. Install the O-rings (58) and (59) on the pump base (62) and insert the intermediate plate (57) into the pump base (62).  
When correctly assembled, no O-ring may be visible through the recesses in the intermediate plate (57).
17. Tighten the pump base (62) with fillister head screws (63).  
Tighten the fillister head screws crosswise with the tightening torque of 10 Nm.
18. Then tighten all screws with a torque of 20 Nm.
19. Screw the retaining plate back onto the base plate and use a suitable screw lock
20. Fix the suction pipe using the corresponding screws. Tighten the screws with a torque of 12 Nm.

## 15.5 Replacing the ball valves and suction pipes

### ► Note

The version of the media valves of the pump PTI-MHD1050 is specified at the end of the operating manual.

The pumps can be clearly identified by the article number on the nameplate!  
The description refers to the item number 53509050.

Mount the spring versions so as to ensure that the balls press on the lower parts of the cage (7).

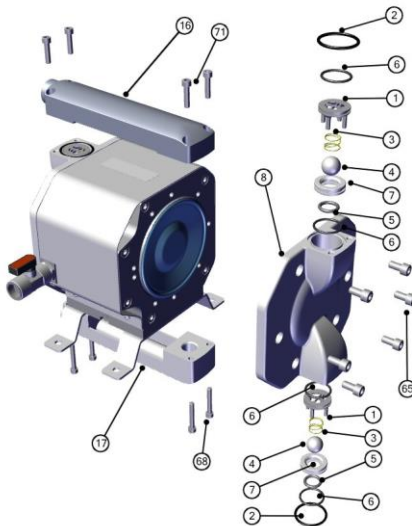

Fig. 12: Replacing the ball valves and suction pipes

1. Loosen the fillister head screws (65 / 68 / 71) at one of the housing covers (8) and remove the cover (8).
2. Remove the O-ring (2) and remove the upper valve cage (1) with the O-ring (6), the spring (3) and the valve ball (4) and the lower part of the cage (7) with the O-rings (5) and (6).
3. Remove the bottom valve cage (1) with O-ring (6), the spring (3) the lower part of the cage (7) with the O-rings (5) and (6) and the valve ball (4).



4. Remove the suction pipe (17) and the outlet pipe (16) with the O-rings (2).
5. Clean the parts with a suitable cleaning agent.  
Previously, check the media compatibility!
6. Check the parts, especially the O-rings for damage and wear.  
Replace defective components.
7. Mount the valve seats with valve ball and O-ring in reverse order.

 **Note**

Do not mix up upper and lower valve!

Observe the mounting direction of the lower parts of the cage (23, 25) and the dimensions of the O-rings (see the detailed views)!

8. Mount the suction pipe (17) and the outlet pipe (16).  
Pay attention to the marking of the low direction.
9. Assemble the housing cover (8) with fillister head screws (65 / 68 / 71).
10. Tighten the fillister head screws crosswise with the tightening torque of 18 Nm.

### **16 Disposal**

#### **16.1 Return shipment**

Please send the pump to the following address:

##### **Timmer GmbH**

Dieselstrasse 37

D-48485 Neuenkirchen, Germany

Germany

#### **Note**

- Please send the pump in the original packaging, to avoid transport damage.
- The pump must be rinsed out and the surface must be clean.
- If rinsing out is not possible, then the media connections must always be tightly sealed to prevent the medium from running out.
- Always include a safety data sheet of the last pumped medium or cleaning agent with the returned pump.

**17 Technical data**

<b>General data</b>	
Operating conditions	+5 ... +40°C at maximum 80% relative humidity
Maximum flow rate	approx. 50 l/min (at 6 bar, free outlet, water)
Drive	Pneumatic
Compression ratio	approx. 3.5 : 1
Fluid connections	¾ " BSP thread (special versions available)
Operating pressure	Maximum 6 bar compressed air, filtered according to DIN ISO 8573
Compressed air connection	Thread G½"
Air connection	Minimum diameter: 13 mm, inside
Suction height, dry	Maximum 4 m
Weight	< 15 kg
Maximum medium viscosity	approx. 15.000 mPa•s
Conveyed medium temperature	+5 ... +65 °C
Sound pressure level	< 70 dB(A)

<b>Material of the parts that come into contact with medium</b>	
Housing	Stainless steel
Pressure pipe	Stainless steel
Diaphragm	Composite membrane PTFE/elastomer*
Ball valve / spring	Stainless steel*
Fluid seal	FEPM*
Valve seat	Stainless steel

\* Other materials such as EPDM, PEEK, FFKM and NBR are available!

**18 Spare parts for standard version**
**18.1 PTI-MHD1050, diaphragm 53509069**

Item	Article number	Quantity	Description	
001	-----	2	High-pressure diaphragm	Wear parts package TimFlex item no. 53509069
002	-----	2	Support disc	

**► Note**

Spare parts are only available in the wear parts packages. The packets vary depending on the selected variant. In this case the spare parts numbers are provided separately.

Use only original Timmer spare parts.

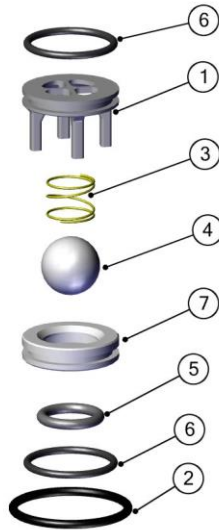

Fig. 13: Replacement parts media valve 53509070

## 18.2 PTI-MHD1050, diaphragm 53509070

Item	Description	Quantity	Article number
1	Cage for ball D20	4	53507013
2	O-ring 36x3	4	70011280
3	Spring 0.8 Di 15 H 21.5 VA	4	79010650
4	Ball 20 V4A	4	70050015
5	O-ring 16x3-5 FEPM	4	70010529
6	O-ring 27x2.5 FEPM	8	70010530
7	Lower part cage for ball D20	4	53509063

---

**Index****A**

About this manual 6  
Areas of applicability 7

**B**

Basic information concerning safety 9

**C**

Check scope of delivery 22  
Cleaning 32  
Commissioning 27  
Compliance with the instructions in the operating manual 10  
Connection 25

**D**

Decommissioning 36  
Dismantling the pneumatic valve 45  
Disposal 50

**E**

EU Declaration of Conformity 5  
Exploded-view drawing 39

**F**

Fault rectification 30  
Foreseeable misuse 13

**G**

Guarantee and warranty 8

**I**

Installation 23

Installation of the pneumatic valve 46  
Intended use 11

**M**

Maintenance 34  
Maintenance schedule 35  
Manufacturer information 7

**N**

Non-intended use 12

**O**

Operation 29  
Operational prerequisites 11

**P**

Personal protective equipment 15  
Personnel qualifications 15  
Preparations 25  
Product description 23

**R**

Rating plate 14  
Regulating the delivery rate 29  
Replacing components 37  
Replacing the ball valves and suction pipes 48  
Replacing the diaphragm 40  
Replacing the pneumatic valve 42

**S**

Safety 9  
Safety instructions 17, 23, 27, 32, 34, 36, 37  
Safety notices in the operating manual 16

## Index

---

Signage on the pump 14  
Spare parts 53  
Storage 22

### T

Technical data 51

Timmer Service 35  
Transport 22

### U

Use and safekeeping 6











**Timmer GmbH**  
Dieselstrasse 37  
D-48485 Neuenkirchen, Germany  
Germany

Tel.: +49 5973 9493-0  
Fax: +49 5973 9493-90  
info@timmer.de

**[www.timmer.de](http://www.timmer.de)**